



SureFire II™ Natural Draught Gas Pilot type SP-48-NG/PG-ND Instruction Manual

1. INTRODUCTION

This Instruction Manual contains a description of the type **SP-48-NG/PG-ND** gas pilot construction, operation principle and the instructions for installation, start-up and service, including the industrial health & safety recommendations.

The **SP-48-NG/PG-ND** (**48** mm outer diameter, **NG** - Natural gas or **PG** - Propane gas, **ND** - natural draught) gas pilot for Natural gas or Propane gas (other Fuel gas on request) is a reliable and effective source of ignition for oil and gas burners (see Appendix 1 – the pilot capacity vs. gas pressure graphs).

Pilot Part Number for Natural gas is “**SP-48-NG-ND-xxx**”, for Propane gas is “**SP-48-PG-ND-xxx**” (other Fuel gas on request) where “-xxx” is the insertion length “L” from 0.5 to 2.0 metres.

The pilot is constructed of high quality materials, and each unit is checked and tested before dispatch.

Acquaintance with the following instructions and strict attention to the indications reduce the possibility of equipment failure to a minimum and ensure safety during normal operation.

FIGURE 1. Gas pilot type SP-48-NG/PG-ND

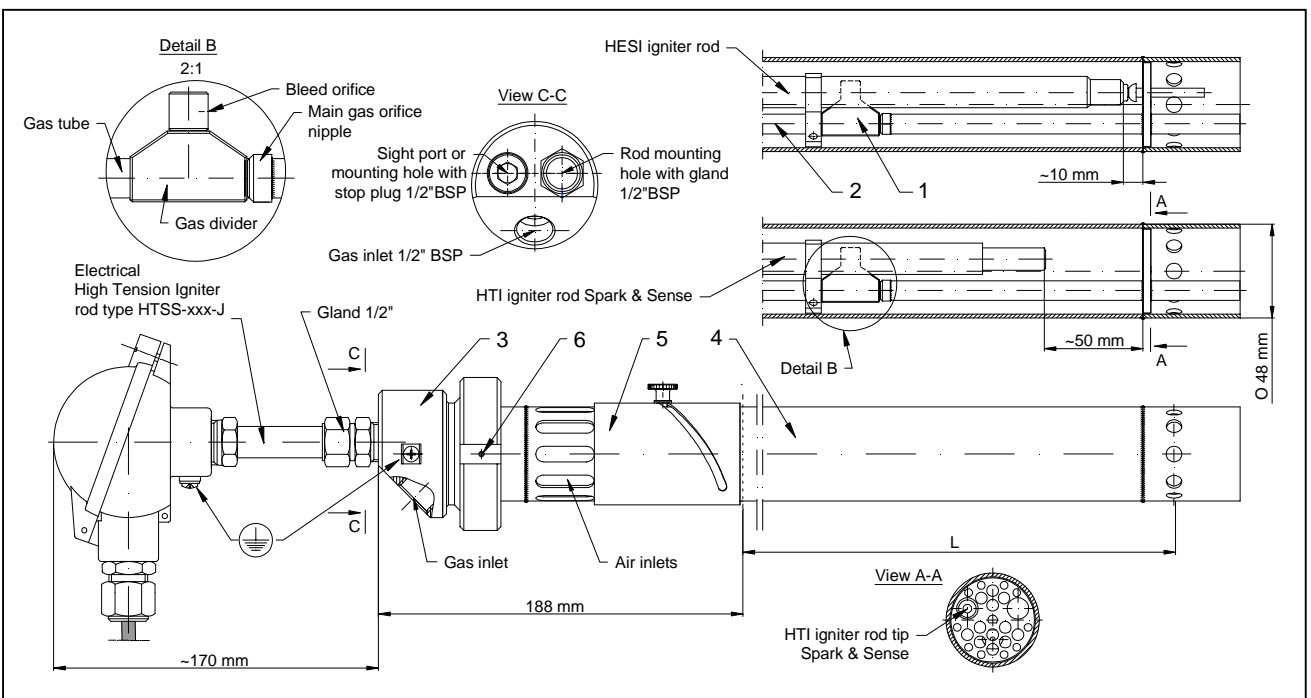

2. OPERATION PRINCIPLE AND TECHNICAL SPECIFICATION

Unit construction provides a stable flame, ignition repeatability. No moving parts ensures long, trouble-free operation with low maintenance costs.

SP-48-NG/PG-ND can operate as an intermittent (light-off), or as a continuous gas pilot.

Main parts of SP-48-NG/PG-ND pilot are: air tube (pos. 4 on Fig. 1) with air inlets covered by sliding adjusting sleeve (pos. 5) and gas part assembly including gas head (pos. 3) with gas inlet (1/2" BSP), ignition rod hole (1/2" BSP) with holding gland and sight port hole (1/2" BSP) with stop plug mounted. It includes also the fixed gas tube (pos. 2) with the orifice-stabilizer assembly (pos. 1) consisting of a gas divider with main and bleed orifices, gas tube and stabilizer. Gas part assembly is mounted in the air tube by means of the thread joint with mounting ring equipped with the small locking screw.

In many applications SP-48-NG/PG-ND is mounted on the main burner in the mounting tube (see p. 3).

The source of ignition is an electrical high energy spark igniter (HESI) or high tension arc igniter (HTI) for safe or hazardous area (depends on the application) equipped with the ignition rods of outer diameter up to 16 mm and co-axial electrode arrangement – see Fig. 3.

The ignition rod is mounted in the gas head and passes through the air tube to the mounting bracket of stabilizer assembly. The rod tip end should be placed as on drawing Fig. 1 (depending on the kind of ignition device), to provide a successful ignition of air-gas mixture.

Gas pilot SP-48-NG/PG-ND can be supplied together with electrical ignition device selected depending on the application. Ignition device is not in gas igniter scope, it is specified separately and should be separately ordered.

SP-48-NG/PG-ND gas pilot principle of use: gas is supplied through the inlet 1/2" BSP to the gas head and to the gas tube and further to the orifice-stabilizer assembly. A small amount of gas leaves through the bleed orifice mounted in the gas divider, into the zone before the stabilizer plate, where it mixes with air to form a combustible mixture. It is ignited in that zone by a spark or an electric arc generated at the tip of the electrical igniter rod. Further it ignites the main stream of gas which exits the main nozzle at the outlet of the air tube. The main flame then stabilizes in the primary combustion zone in front of the stabilizer of sieve type which provides an adequate shape and stability of the flame.

Orifice and stabilizer assembly is optimized for Natural gas or Propane gas. In case of other Fuel gas contact Fireye as this may need the orifice replacement or changes in entire assembly.

Thanks to this principle of design, the pilot combustion zone is protected, the main combustion zone is outside the igniter, and hence the air tube does not become hot there is no need for retraction of the ignition rod.

The flame length is 0.4 – 0.6 m depending on the kind of gas, gas pressure and pressure in the combustion chamber.

In addition, using Fireye high tension igniter type HTSS in Spark & Sense version, the center electrode of igniter rod is also an ionization rod extended into the primary combustion zone and specially designed to work with SureFire II Pilots.

The HT igniter initially creates the electric arc to ignite the gas, and then the circuit switches the operating mode for ionization detection, confirming the presence of the igniter flame.

FIGURE 2. Pilot mounting tubes: for welding and flanged

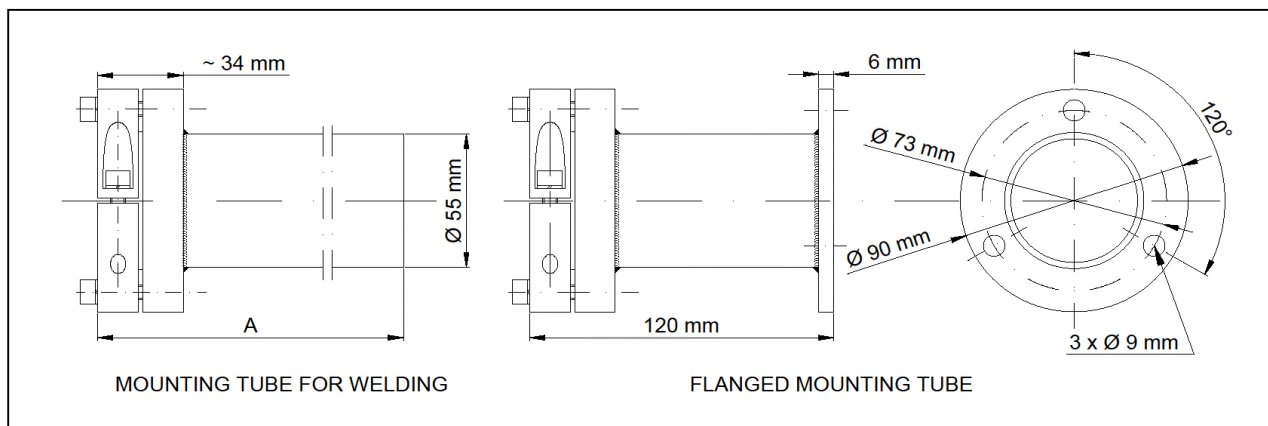

3. MOUNTING TUBES

For fixing the pilot burner to a burner plate there are two types of mounting tube (material: carbon steel, grease protected), being an optional accessory, to be ordered separately:

- a flange mounting tube allowing the fixing of a gas pilot without the use of welding (Fig. 2), to be fixed with the bolts to the burner plate. After inserting the pilot into the mounting tube its position is determined and secured with a clamping ring located at the end of the tube assembly. This ring also provides the necessary sealing for the connection.
- pilot mounting tube for welding (Fig. 2), to be fixed to the burner plate by means of welding. Pilot fixing inside mounting tube as in p. 7.1. There are two lengths A: 150 and 600 mm.

4. IGNITION SOURCES FOR GAS IGNITER LIGHT-OFF (SETTING METHOD)

Sources of ignition of the gas in the gas pilot SP-48-NG/PG-ND are electrical high energy spark igniters (HESI) or high tension igniters (HTI) equipped with the ignition rods of outer diameter up to 16 mm and coaxial electrode arrangement (see Fig. 3):

- high energy spark igniter (HESI): this type of device creates single sparks of a high energy of 12J. With frequency of 4 to 5 sparks per second it ensures reliable ignition of a gas/air mixture under all conditions. The secondary circuit voltage is nominally 2 000 VDC at primary supply 230 or 110 VAC,

FIGURE 3. Gas pilot type SP-48-NG/PG-ND with examples of electrical ignition devices

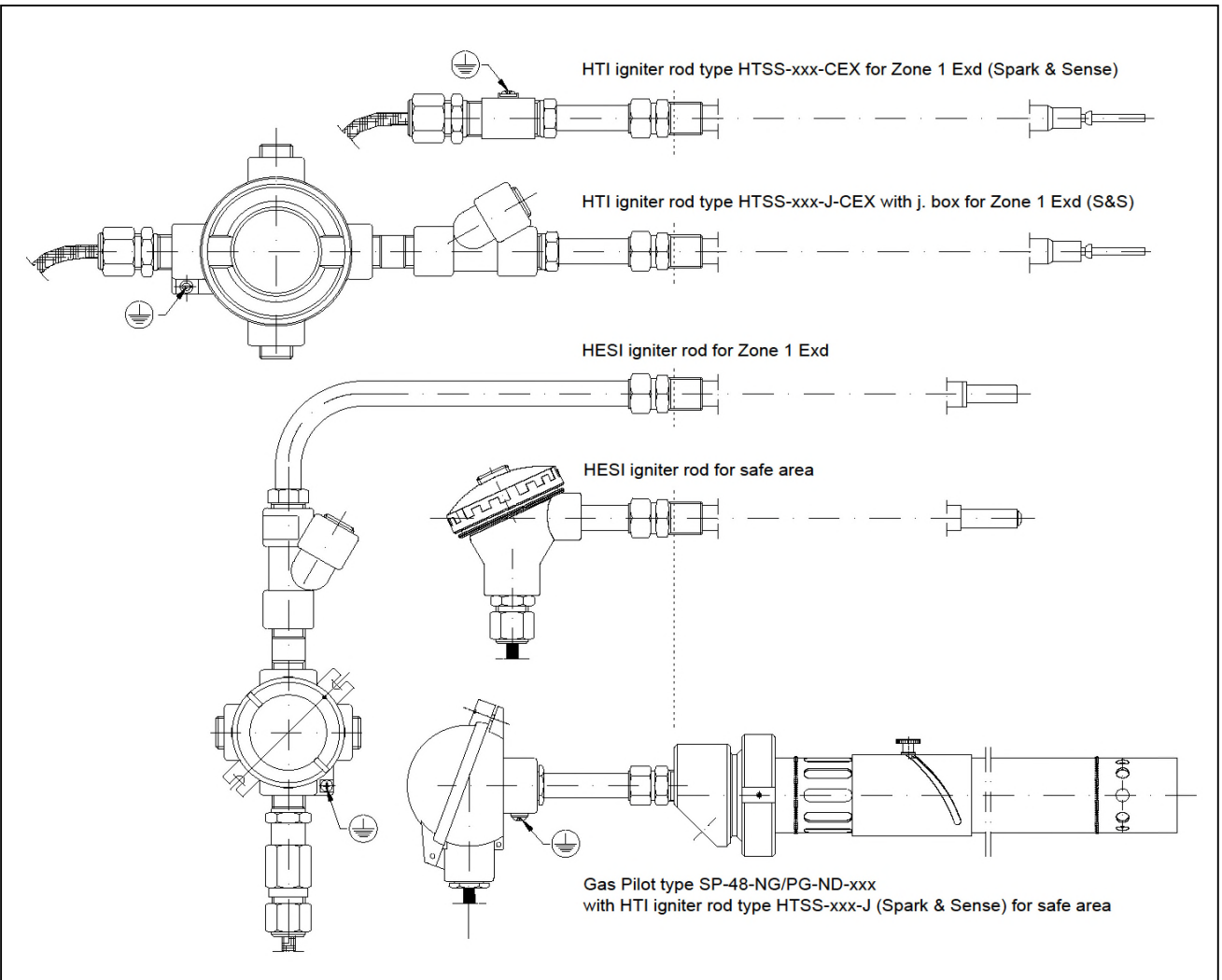



- high tension igniter (HTI): this type of device creates an electrical arc of low energy which allows for ignition of a gas/air mixture in clean environment and repeatable conditions. The secondary circuit voltage is 8 000 VAC at primary supply 230VAC or 110 VAC.

High Energy Spark Igniter rod should be fitted such that the tip end should be placed at a distance of ~50 mm back from the stabilizer plate. High Tension Igniter should be placed closer to the stabilizer plate, at a distance of ~10 mm.

It should be noted that the rod tip positioning against the stabilizer plate in the pilot gas part assembly (pos. 3 on Fig. 1) should be done outside the air tube only (do not install the rod in the gas head already mounted in the air tube). Only after proper rod positioning, the rod can be fixed by tightening the rod holding gland and the whole gas assembly with igniter rod inserted into the air tube pos. 4.

The rods of both types of devices are held in the gas head by means of the fixing gland 1/2" BSP.

Ignition device is not in gas igniter scope, it is specified separately and should be separately ordered.

5. TECHNICAL DATA

Fuel	Natural Gas/Propane Gas - other fuel gases upon request
Outer diameter of the air tube	48.0 mm
Outer diameter of the mounting tube	55.0 mm
Outer diameter of the ignition rod	≤16.0 mm
Capacity range:	Natural Gas: 20 ÷ 46 kW at 20 ÷ 80 kPa (see Appendix 1)
	Propane Gas: 35 ÷ 74 kW at 20 ÷ 80 kPa (see Appendix 1)
	- other fuels and capacities upon request
Air flow and pressure	natural draught
Gas connection	1/2" BSP (inner thread)
Igniter rod reference length range "L"	0.5 ÷ 2.0 m - longer upon request
Material used for construction	all parts: 304/316 SS and heat-resistant steel 310/330 SS

- Notes:**
1. If the above parameters are different than those required please contact Fireye
 2. For Imperial Units please refer to the Appendix 3 Unit Conversion Table
 3. Device comply with the requirements of the European Directive 2011/65/EU (RoHS 2)

6. OPERATIONAL SAFETY

When operating and handling the pilot burner please follow the rules below:

- 6.1 Use pilot only for its intended purpose.
- 6.2 At the time of installation, operation and maintenance follow the procedures described in the instructions and documentation of the pilot, ignition device and the main burner.
- 6.3 Follow the warnings contained in the documentation.
- 6.4 Do not make any modifications or changes to the pilot construction.
- 6.5 Before starting, make sure that all parts of the pilot and electric ignition device are in good condition.
- 6.6 Circuits of power packs as well as igniter enclosures and junction boxes must be properly grounded.
- 6.7 Before igniting, check the tightness of gas tube connections.
- 6.8 During the observation of the pilot flame wear special goggles to protect the eyes from UV radiation of the flame.
- 6.9 Do not remove the protective ground when the ignition device is energized.
- 6.10 Before working on the ignition device, make sure that power is disconnected.
- 6.11 Before maintenance or repair works check if the gas shut-off valve is closed.
- 6.12 During installation, start-up or maintenance works on the pilot or burner/heater always wear protective clothing and use protective gloves.



WARNING: ALL ACTIONS RELATED TO THE INSTALLATION, SERVICE AND OPERATION OF GAS PILOT MAY ONLY BE CARRIED OUT BY A TRAINED AND QUALIFIED PERSONNEL.

7. INSTALLATION

During the installation, all components must be protected from impact or bending.

Pilot SP-48- ND is designed such that it can be welded directly to the burner plate, or placed in the mounting tube (see Figure 2).

It should be noted that the insertion depth should be fitted in a manner that will allow full air adjustment by adjustment sleeve (insertion depth cannot exceed the “L” value – see Fig. 1).

Pilot air tube is made of stainless steel, mounting tube is made of carbon steel which must be noted for welding.

REMARK: IN CASE OF ANY DOUBTS REGARDING INSTALLATION OF THE PILOT CONSULT WITH THE MANUFACTURER.

7.1 MOUNTING TUBE

The mounting tube, if used, should be attached to the burner plate using bolts or welding (see Fig. 2). If it is not possible to use one of mounting tubes proposed above, a different type can be used, bearing in mind that its inner diameter should be properly matched to the outer diameter of the pilot air tube to be able to fit and fix the pilot in a tube with proper clearance.

In case of an application including a mounting tube proceed in the following way:

- a) Based on assembly drawings mark and cut a hole in the burner plate with a diameter slightly larger than the diameter of the mounting tube.
- b) The mounting tube for welding: slide the mounting tube in the hole and set it in the correct position (insertion depth and proper angle relative to the main burner nozzle position).
- c) The mounting tube for welding: weld using the electrode appropriate for the material.
- d) If the flanged mounting tube is used, bolt it to the burner plate after drilling the correct sized holes.
- e) For both types of mounting tube the clamp assembly with screws and gasket provides a fast and reliable mounting and dismantling of the pilot.

7.2 GAS ASSEMBLY AND AIR TUBE

- a) The position of the electrical igniter rod tip in relation with the stabilizer assembly of pilot should be checked following information in p. 4. The correct position for different types of electrical igniter rods should be taken into consideration (see Fig. 1).

It should be remembered that the rod tip positioning against the stabilizer plate in the pilot gas part assembly (pos. 3 on Fig.1) should be done outside the air tube only.

Only after proper rod positioning, the rod can be fixed by tightening the gland and the whole gas assembly with rod inserted into the air tube.

- b) In case of necessary corrections loosen the rod holding gland and set the appropriate position. If the rod of electrical igniter is supplied separately, insert the rod in rod holding gland and then in gas part assembly mounting bracket and set the appropriate tip position following the above instructions. If there are problems sliding the rod through rings of fixing gland apply a small amount of high temperature resistant grease or grind slightly the gland ring inner surface.

After setting the correct rod position, fasten the rod fixing gland in the gas head.

Then the complete gas part assembly can be slid into the air tube.

Do not remove the rod from fixing gland if it is not necessary as the gland rings once clamped on rod do not allow easy rod movement.

- c) Gas part assembly and air tube should be fastened by the mounting ring thread joint. Ensure that the ring gasket is correctly fitted in the gas head seat (see Fig. 4). The mounting ring small locking screw (pos. 6 on Fig. 1) should be tightened to prevent the ring from accidentally unfastening.
- d) The complete pilot (air tube) can be inserted into the mounting tube. In order to make the air tube slide-in easier apply a small amount of high temperature resistant grease.
- e) The insertion depth of SP-48-ND pilot is determined by the design of the main burner. If an existing pilot has to be replaced, the insertion length and pilot tip position should be the same. In case of any doubts, the position of the pilot should be checked with the pilot and burner manufacturer.
- f) After determining the position of the complete pilot relative to the mounting tube, the mounting tube clamping screws should be tightened to prevent the device from moving.

FIGURE 4. Gas head with ring gasket and orifice-stabilizer assembly with bleed and main gas orifices

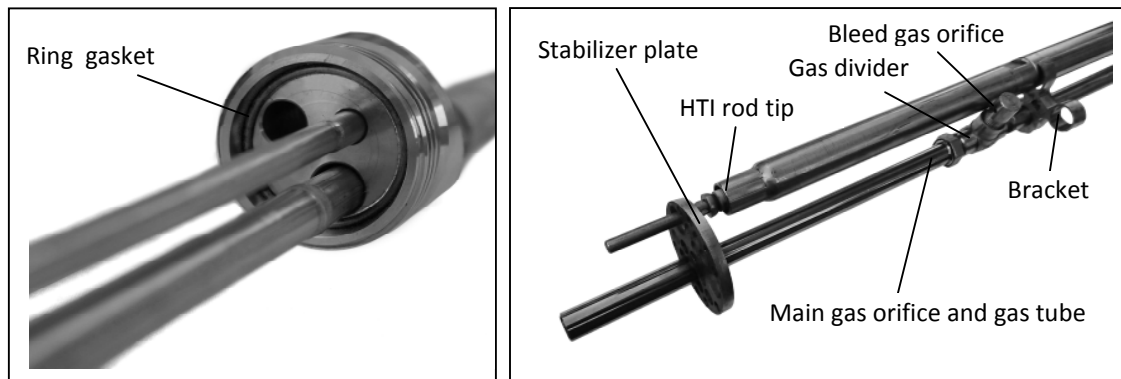

7.3 GAS SUPPLY INSTALLATION

- a) The pilot must be set in the mounting tube such that the gas connection is in the desired position.
- b) Connect the gas hose to the appropriate pilot input. The hose must not be tangled or twisted. If necessary, additional connectors may be used.
- c) To ensure a long and trouble-free operation of the pilot it should be kept clean. Take care of the gas tube and orifices patency. The gas hose should be dry and not cracked.
- d) During maintenance or service works, secure the disconnected end of the hose by closing the end with a plug or a tape.
- e) Use the automatic shutoff valves of the appropriate size and the respective closing rate and pilot gas pressure measurement with safety interlocks (compliant with the requirements of relevant standards concerning the shut-off safety fuel valves and burner safety) to be sure that the gas delivered to the pilot is of an adequate pressure and can be quickly and effectively shut off.
- f) Use a manual shut-off valve on gas line for each pilot in case of maintenance or replacement and for adjustment of pressure and flow on each pilot separately.

REMARK: AT DESIGN STAGE DETERMINE LENGTH OF CABLES AND FLEXIBLE AIR AND GAS CONNECTIONS TO ACCOMMODATE ANY EXPECTED HEATER OR BOILER CONSTRUCTION MOVEMENT

7.4 CABLING

Wiring and electrical connections design and layout should be in accordance with the requirements for burner installation devices specified in their instructions and the relevant regulations.

8. PILOT START-UP, OPERATIONAL TESTS

Before proceeding with the start-up and operational tests of SP-48-NG/PG-ND pilot check the following:

- 8.1 Gas installation is properly mounted, tight and functionally checked, including: valves, flaps, strainers, fittings and joints (flanged and screwed) as well as control and interlock devices.
- 8.2 Gas connection to the pilot is made in accordance with the above instructions and the assy drawing.
- 8.3 Electrical components and circuits are properly connected, grounded and tested.
- 8.4 Power supply to the electrical circuit of the ignition device and spark or arc release should be allowed only after assembly of the device, in the operating position on the burner or outside the burner only to validate the operation strictly according to the device instructions e.g. on test stand.

Then perform next steps:

- 8.5 Select one pilot as a representative for tests.
- 8.6 Prepare the burner control system to enable manual trials in a safe way.
- 8.7 Install for the trial period appropriate gauge and manual valve on the pilot gas supply line. This will allow for fine adjustment of the gas pressure.
- 8.8 After verification of ignition device mounting and wiring, the electric igniter can be powered up. Check for the spark or arc presence.
- 8.9 At presence of a spark or an electric arc from ignition device, slowly open the pilot manual shut-off gas valve with the air inlets obscured by adjusting sleeve completely (pos. 5 on Fig.1). At certain degree of opening the pilot flame should establish.
- 8.10 Adjust the gas pressure slowly up to the working pressure. Pilot flame may be yellow and bushy due to too little combustion air.
- 8.11 Adjust the air sleeve until the flame stabilizes at the air tube end and reaches blue-yellow color. The air tube should not glow - if this happens adjust the air and gas or eventually the main burner air pressure (in the windbox) to stabilize the flame in the desired position and to stop the glow effect. Flame should be as stable as possible.

Remarks:

- a) Pilot flame should be blue near the igniter tip and yellow at his end. With some kind of gases the flame color may stay yellow.
 - b) In some applications e.g. on up-fired burners, when the draught of the furnace is significant, it may be necessary to limit the amount of air by obscuring air inlets accordingly in order to keep stable pilot flame, bearing in mind, that air adjustment possibility of natural draught pilot is limited.
 - c) A gas pilot, after correct adjustments, should ignite reliably and burn with a stable flame at each selected gas pressure point throughout his operational pressure range. However, it should be noted that, the pilot is not intended to be used as a burner - his turn-down ratio is typically 1:1.
- 8.12 In case of insufficient pilot capacity, the amount of gas and air can be further adjusted bearing in mind the above principles.
 - 8.13 In multiple burner and pilot applications on one heater/boiler with a similar gas supply installation and similar layout on the main burner, set the other pilot's gas manual valve and the air adjusting sleeve to the same position.
 - 8.14 Then carry out light-off tests. In case of differences in the quality of combustion adjust manual valve and air sleeve so that the flame is similar to that on the test pilot. In some cases the main burner air should be adjusted.
 - 8.15 Repeat the light-off tests several times on each pilot to confirm the repeatability of ignition. Flame should be stable, in correct position and of desired shape.
 - 8.16 For outdoor installation, pay attention to the influence of wind strength and direction on the quality of the pilot flame. In the event of its significant impact appropriate measures should be taken, e.g. in the form of fences around the burners or heater limiting this influence.

If the SP-48-NG/PG-ND gas pilot has been properly started and the settings were optimized, with correct maintenance, the igniter will operate trouble free.



9. OPERATION

After installing and completion of pilot start up and tests SP-48-NG/PG-ND is ready for operation.

General description of activities performed by the burner/boiler control system or manually by the operator:

- 9.1 Preparation the furnace/boiler for firing up.
- 9.2 Opening of air to the burner and pilot.
- 9.3 Preparation of gas installation for operation.
- 9.4 Setting the gas pressure at the right level.
- 9.5 Starting of pilot trial for ignition sequence performed by the controller or in some cases by the operator:
 - a) The correct setting of the main burner combustion air,
 - b) Checking the interlock conditions before firing up,
 - c) Providing power to the ignition source,
 - d) Optionally, carrying out the gas line leakage test,
 - e) Closing the purge valves and opening of gas shut off valves,
 - f) The ignition should take place within the time specified by the standards, which should be confirmed by the relay output of the flame detector,
 - g) Electrical igniter power off after confirming the presence of the pilot flame, closing the pilot shut off valves (in case of continuous pilot operation they stay open),
 - h) In case of the absence of the flame after trial for ignition - the valves are closed and electrical igniter is switched off,
 - i) Eventual repeating of trial for ignition sequence (depends on the application). Details of sequence, timing is dependent on application and standard applied.

In the case of the manually controlled gas pilot the operator has to close the gas supply to the pilot by himself at the right time if the flame is not detected.

10. SERVICE, MAINTENANCE AND REPAIRS

To remove the pilot for inspection or repair the gas and electrical supply has to be shut off first. Check that the gas shut off valve is closed and that the power for ignition device is disconnected.

WARNING: DO NOT PERFORM ANY MODIFICATION OF THIS PRODUCT ON YOUR OWN AND DO NOT USE OTHER PARTS THAN ORIGINAL.
DANGER TO LIFE AND HEALTH !

WARNING: WHEN THE HEATER/BOILER IS IN OPERATION, DURING SERVICE WORKS ON BURNER INSTALLATION ALWAYS USE PROTECTIVE CLOTHING, GLOVES AND GOGGLES!

REMARK: EVERY 12 MONTHS MAKE AN INSPECTION OF AIR TUBE. IF YOU SEE ANY TRACES OF TOO HIGH TEMPERATURE DURING OPERATION INCREASE THE COOLING-COMBUSTION AIR FLOW OR RETRACT THE GAS PILOT A LITTLE FROM THE COMBUSTION CHAMBER. INCREASING THE AMOUNT OF AIR REMEMBER THAT IT MAY HAVE THE BAD EFFECT ON THE FLAME QUALITY.

10.1 INSPECTION AND MAINTENANCE

Pilot SP-48-ND because of simple design does not require complicated maintenance procedures.

Checking and cleaning of air and gas tubes:

- a) Close the manual gas valve and disconnect the pilot gas line.
- b) Disconnect the ignition rod electric supply cable.
- c) Unscrew the locking screw and the mounting ring.
- d) Carefully slide out the gas part assembly from the air tube.
- e) Pull out the electrical igniter rod by loosening the ignition rod holding gland, only if it is absolutely necessary e.g. when rod is worn or damaged and has to be repaired or replaced.
- f) Check and clean the bleed and main gas orifices. For cleaning use a soft copper wire.
- g) To remove heavy dirt use a soft wire brush e.g. copper wire brush.
- h) Blow compressed air through the whole gas part assembly.
- i) To check the air tube condition loose the mounting tube clamp assembly screws and pull out air tube. Check for overheating traces and clean it.
- j) Assemble all the elements back to obtain the original configuration.

Checking of ignition device:

- k) Check the ignition rod at least every 12 months. Follow the instructions in the ignition device User's Manual.

10.2 TROUBLESHOOTING

If the gas pilot does not work properly check first whether:

- a) All manual gas valves on gas supply line were open and there is gas available.
- b) All valves in the supply line are functioning properly.
- c) The preset gas pressure is correct.
- d) Is there a significant influence of external conditions on the amount of air supplied to the pilot.
- e) Gas supply lines are clear - check strainers.
- f) Gas orifice in orifice nipple is clear.
- g) Electric ignition device is working properly and its rod is correctly positioned in gas part assembly. If it is not working properly - follow the ignition device manual.
- h) The power parameters for ignition device are correct.

If the gas lights but the flame is unstable, or goes out when main burner goes into operation, check that:

- i) The gas pressure does not drop during pilot light-off (trial for ignition).
- j) There is no significant interference of the air flow around the pilot.
- k) The air from the main burner does not blow off the pilot flame or does not move it out of the field of view of the flame scanner (if applied).
- l) Flame safeguard system works correctly and the flame is not obscured.

Improper operation of the whole installation requires the detailed checking of the power line, all components, including the temporary use of override switches or bridges.

Be aware of all connections to be later restored to normal state, to allow safe operation.

10.3 SPARE PARTS

For start-up and warranty period it's recommended to order following spare parts in quantity as below:

- a set of loose parts used on both sizes on pilots: SP-32 and SP-48 (see Fig. 5) - one for 4 pilots,
- complete orifice-stabilizer assembly for SP-48-ND pilot, including: main orifice nipple with gas tube, bleed orifice, stabilizer, divider - one for 4 pilots.

In case of air tube wear order on request a replacement air tube (without mounting ring) of length "L".

If just the end of air tube is eroded by temperature cut 200 mm of the tube tip and weld spare part P/N SP-48-ND-END - replacement air tube end, length 200 mm, SS316.

List of pilot spare parts Part Numbers is in Table 2.

FIGURE 5. Loose Spare Parts set for SP-32 and SP-48 pilots

- Loose Spare Parts set includes:
- 1 - rod gland 1/2" NPT – 1 pc
 - 2 - locking screw M4 hex – 3 pcs,
 - 3 - hex key 2mm – 1 pc
 - 4 - gasket OD 25x5 (for SP-32) – 1 pc
 - 5 - O ring 46x3 (for SP-48) – 1 pc
 - 6 - thumb screw M4 with two washers (for SP-32-ND and SP-48-ND) – 1 pc

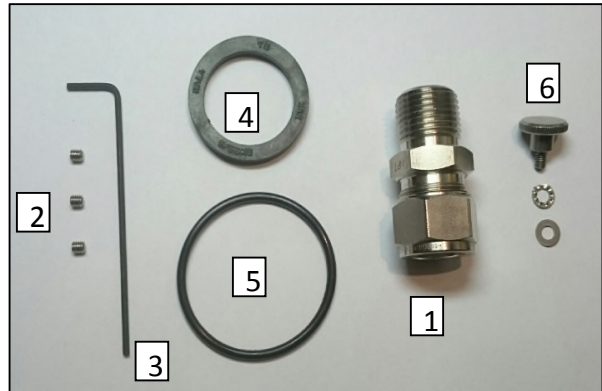

11. STORAGE

SP-48-NG/PG-ND gas pilot should be stored in a clean and dry place and in its original packaging if possible.

In case of long length pilots always keep it in a horizontal position by supporting both ends and in the middle. It should also be protected from contamination using caps on gas and air inlet and pilot outlet and covering it with foil.

Storage over 30 days: relative humidity of no more than 85%, temperature below 50°C.

12. ORDERING INFORMATION

Before ordering, please provide the data as in Appendix 2.

The Table 1 below shows examples of the Part Numbers of length “L” every 0.5 metre and the fuel options of Natural Gas or Propane Gas.

Pilots can be ordered in size increments of 0.1 metre lengths, from 0.5 to 2.0 metres.

Part Number coding samples:

SP-48-NG-ND-1.5 or SP-48-PG-ND-1.5

which means: SureFire II Pilot - 48 mm OD - Natural Gas (NG) or Propane Gas (PG) - Natural Draught - 1.5 metre insertion length.

Table 1: SureFire II Natural Draught Pilot selection Table, showing only the 0.5 metre intervals, 0.1 metre intervals may be ordered (See Price List).

REMARK: Select required kind of fuel. Select Electrical Igniter rod and power pack separately

Part No	Description
SP-48-NG/PG-ND-0.5	SureFire II Pilot, 48 mm OD, Natural Gas or Propane Gas, Natural Draught, 0.5 m Insertion length
SP-48-NG/PG-ND-1.0	SureFire II Pilot, 48 mm OD, Natural Gas or Propane Gas, Natural Draught, 1.0 m insertion length
SP-48-NG/PG-ND-1.5	SureFire II Pilot, 48 mm OD, Natural Gas or Propane Gas, Natural Draught, 1.5 m insertion length
SP-48-NG/PG-ND-2.0	SureFire II Pilot, 48 mm OD, Natural Gas or Propane Gas, Natural Draught, 2.0 m insertion length

Table 2 below shows Part Numbers of gas igniter mounting tubes and spare parts.

Table 2: SureFire II Pilot Mounting Tubes & Spare Parts

Part No	Description
SP-48-MTF	Mounting Tube Flanged, flange OD 80, length 120mm
SP-48-MTW-150	Mounting Tube for Welding, length 150 mm
SP-48-MTW-600	Mounting Tube for Welding, length 600 mm
SP-32/48-LS-SET	Loose Spare Parts set for SP32 and SP-48 pilots *
SP-48-ND-STOR	Orifice-stabilizer assy: stabilizer, divider, main gas orifice w. gas tube, bleed orifice, for SP-48-ND
SP-48-ND-END	Air tube end with inlets, 200 mm long, SS316, for SP-48-ND

* Loose Spare Part set includes items as on Fig. 5

APPENDIX No 1

The pilot capacity vs. gas pressure graphs

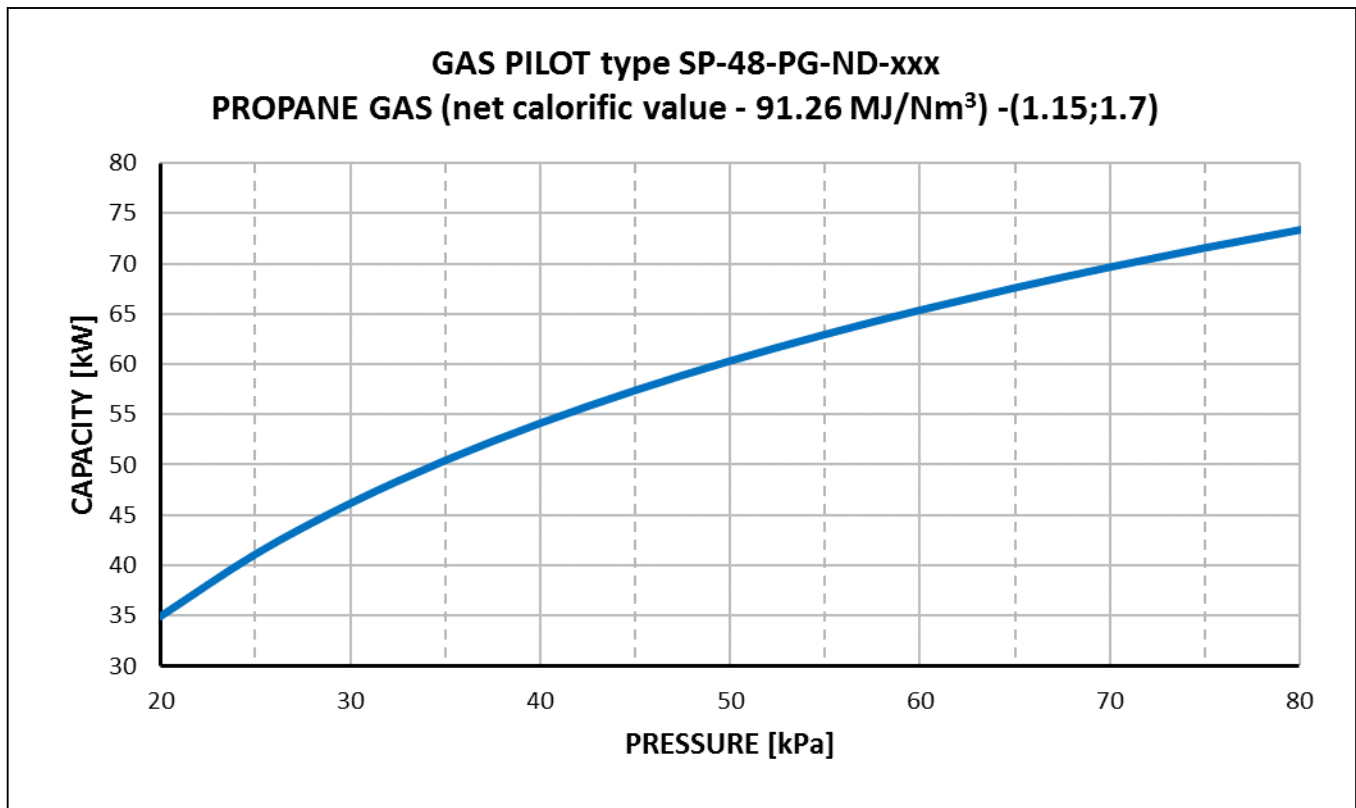
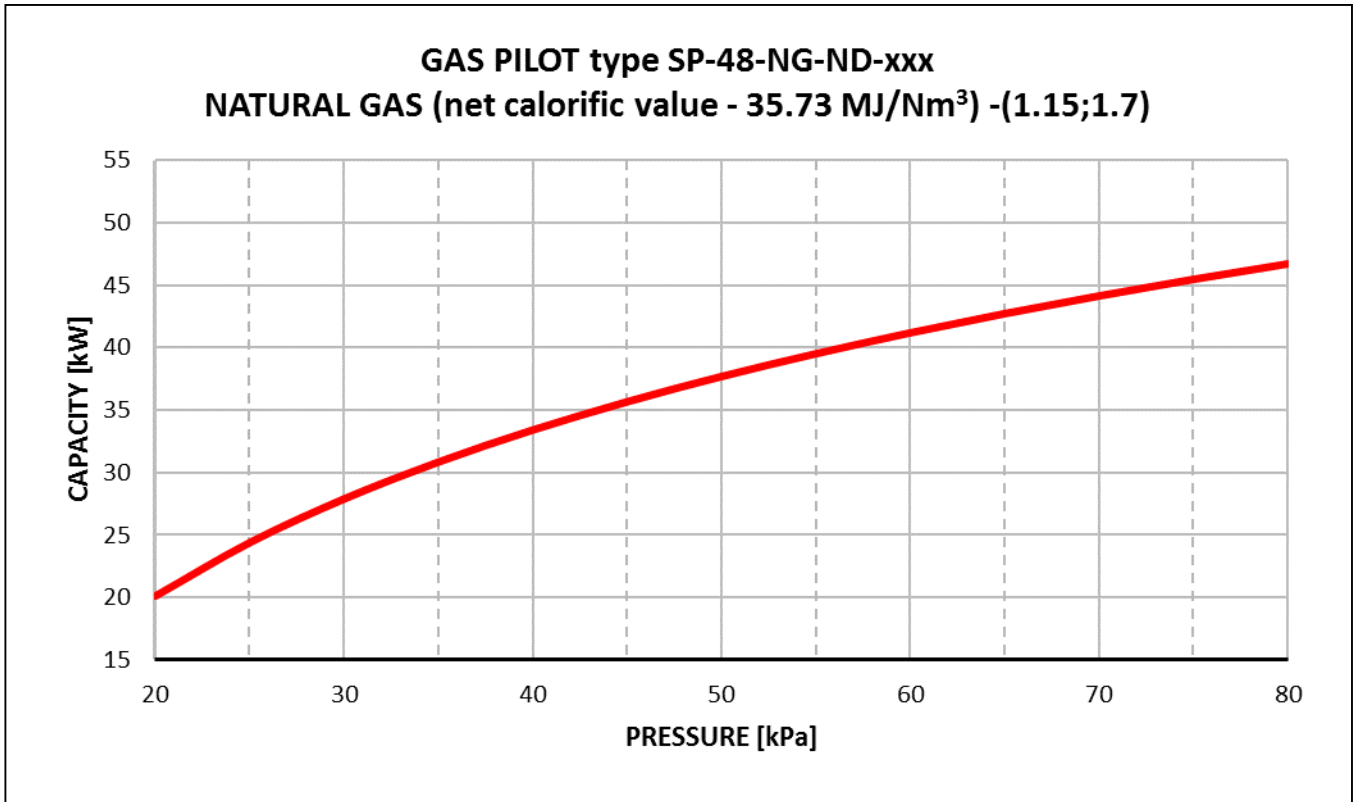



APPENDIX No 2

Proposal Data Sheet

SureFire II™ Pilot - Natural Draught Gas Pilot
type SP-48-NG/PG-ND-xxx

Please provide the following data before placing the Order for gas pilot:

1.	Information about End User		
	— Plant Name:	
	— Owner:	
	— Country:	
	— Localization (address):	
2.	Gas pilot mode of operation:	— intermittent light-off	<input type="checkbox"/>
		— continuous pilot	<input type="checkbox"/>
3.	Insertion length “L”: <i>(see Fig. 1)</i>	[m]
4.	Fuel gas for pilot:		
	— Natural Gas, Propane Gas, other Fuel Gas:	NG <input type="checkbox"/>	PG <input type="checkbox"/> FG <input type="checkbox"/>
	— if other Fuel Gas – specify the type of gas: <i>enclose gas composition sheet</i>	
5.	Gas net calorific value:	[MJ/Nm ³]
6.	Required pilot heat input (capacity):	[kW]
7.	Gas pressure range available for pilot:	[kPa]
8.	Main burner nominal (or max.) capacity: <i>capacity of burner to be lit</i>	[kW]

APPENDIX No 3

UNIT CONVERSION TABLE

Quantity	Metric Units	Imperial Units	
Length	1 millimetre [mm]	x 0.003281 = foot [ft; ']	x 0.03937 = inch [in; "]
	1 metre [m]	x 3.281 = foot [ft; ']	x 39.370 = inch [in; "]
Volume	1 cubic metre [m ³]	x 35.315 = cubic foot [ft ³]	
Air flow rate	1 cubic metre/hour [m ³ /h]	x 0.589 = standard cubic foot/min [SCFM]	
Weight	1 kilogram [kg]	x 2.2046 = pound [lb]	
Pressure	1 kilopascal [kPa]	x 6.895 = pound square inch gauge [psig]	x 4.015 = inch H ₂ O
Power (capacity)	1 kilowatt [kW]	x 293.1 = million BTU/hr [mmBTU/Hr]	
Calorific value	1 megajoule/cubic metre [MJ/m ³]	x 26.839 = BTU/ cubic foot [BTU/ft ³]	
Temperature	Deg. Celsius [°C]	<i>Formula: °C x 1.8 + 32 = Deg. Fahrenheit [°F]</i>	

- This page intentionally left blank -



NOTICE

When Fireeye products are combined with equipment manufactured by others and/or integrated into systems designed or manufactured by others, the Fireeye warranty, as stated in its General Terms and Conditions of Sale, pertains only to the Fireeye products and not to any other equipment or to the combined system or its overall performance.

WARRANTIES

FIREYE guarantees for *one year from the date of installation or 18 months from date of manufacture* of its products to replace, or, at its option, to repair any product or part thereof (except lamps, electronic tubes and photocells) which is found defective in material or workmanship or which otherwise fails to conform to the description of the product on the face of its sales order. **THE FOREGOING IS IN LIEU OF ALL OTHER WARRANTIES AND FIREYE MAKES NO WARRANTY OF MERCHANTABILITY OR ANY OTHER WARRANTY, EXPRESS OR IMPLIED.** Except as specifically stated in these general terms and conditions of sale, remedies with respect to any product or part number manufactured or sold by Fireeye shall be limited exclusively to the right to replacement or repair as above provided. In no event shall Fireeye be liable for consequential or special damages of any nature that may arise in connection with such product or part.



FIREYE®
3 Manchester Road
Derry, New Hampshire 03038 USA
www.fireeye.com

SF-500
APRIL 10, 2018
Supersedes May 30, 2017